

How to determine the correct type, height, and amount of SPRINGPRESS

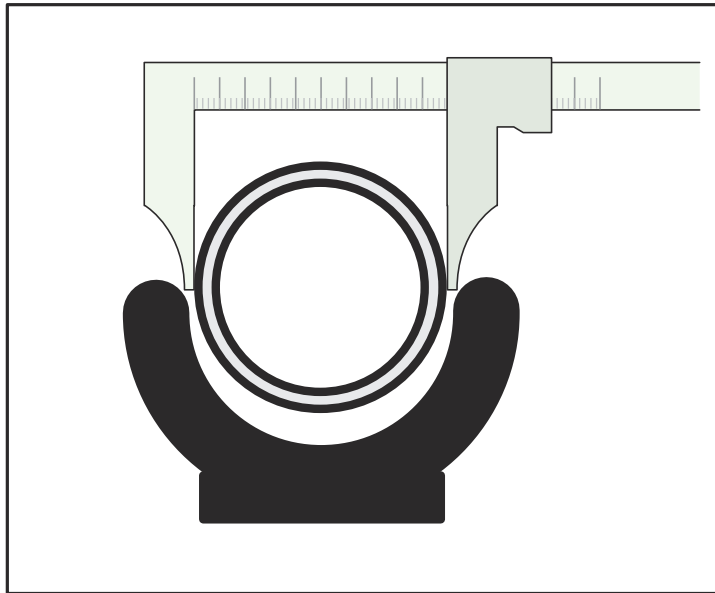

Type

SPRINGPRESS type "H" is designed for machines with working pressure of over 120 g/cm².

Type "H" also must be used on ironers where no pre-compression of the springs is possible. Type "H" should be used on all American type flatwork ironers as well as Calor. SPRINGPRESS type "H" can also be used where very high finish is desired.

SPRINGPRESS type "S" is designed for all machines with working pressure below 120 g/cm². Type "S" gives a pre-compression of as much as 2 mm. Type "S" gives a smooth finish for all flat work, and should be used on all European designed deep chest ironers, except Poensgen and HKC.

Height

The thickness of the padding is the sum of the height of the springs and the thickness of the textile, which is also the difference in the radius of the chest and the radius of the bare roll.

Since it is very difficult to measure the radius of the chest and the bare roll, we suggest you to measure the thickness of the padding using a depth gauge. If no depth gauge is available, use a steel nail and a hammer. After determining the thickness of the padding, measure with spacers the free space between the chest and the back of the roll.

The sum of these two figures gives the thickness that the springs and the padding should be. From this ideal thickness subtract the thickness of the textile to be used, and you will have the resulting height of SPRINGPRESS to use.

For example, if the padding thickness should be 15 mm and you use two wraps of textile 950 g/m² which will be 4 mm after break-in period, you will need SPRINGPRESS springs of 11 mm height. If it is desired to work with one mm pre-compression on the “S” type you may add 1 mm to the height of the spring.

Attention: all measurements must be taken while the ironer is hot.

Amount

For type “H”, 80 metres of SPRINGPRESS is needed to cover one square metre.

For type” S”, 68 metres is necessary.

The following are the proper formulas to determine the length of SPRINGPRESS strip needed to cover one ironer rail.

Type “S” : roll diameter in metres times the roll length in metres times 3.14 times 68 equals length needed in metres.

Type “H” : roll diameter in metres times the roll length in metres times 3.14 times 80 equals length needed in metres.

For example: diameter 600 mm (0.6 m), 3 m length:

$$0.6 \text{ m} \times 3 \text{ m} \times 3.14 \times 68 = 385 \text{ m, type” S”}$$

$$0.6 \text{ m} \times 3 \text{ m} \times 3.14 \times 80 = 452 \text{ m, type “H”}.$$

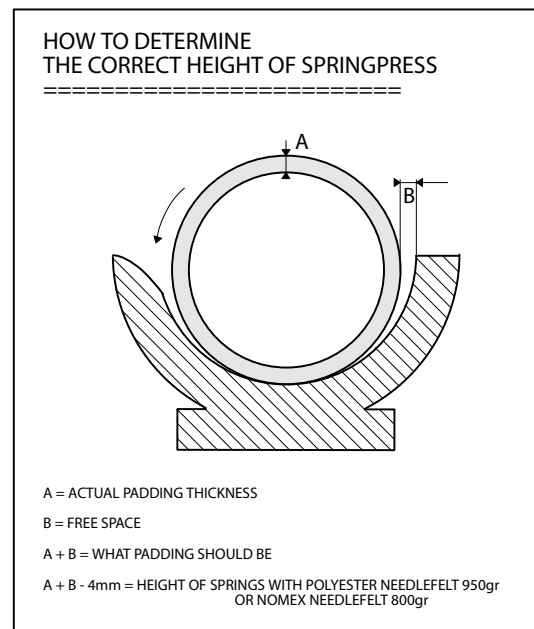

Ottergemsesteenweg-Zuid 702
BE-9000 Gent - Belgium
Phone: +32 9 220 15 11
Fax: +32 9 222 43 40
www.springpress.com